

## Features

- High efficiency switch mode power supply
- Highly stable constant current output
- Suitable for driving 1 to 4 LED lamps at 700 mA
- Class II protection against shock from direct or indirect contact
- Protection against over-load
- Short circuit protection
- Protection against over temperature
- Automatic resetting after fault removal
- Long life > 3 years
- Compact fully enclosed housing
- Individual high and low voltage terminal covers with cable grip

## Package Outline

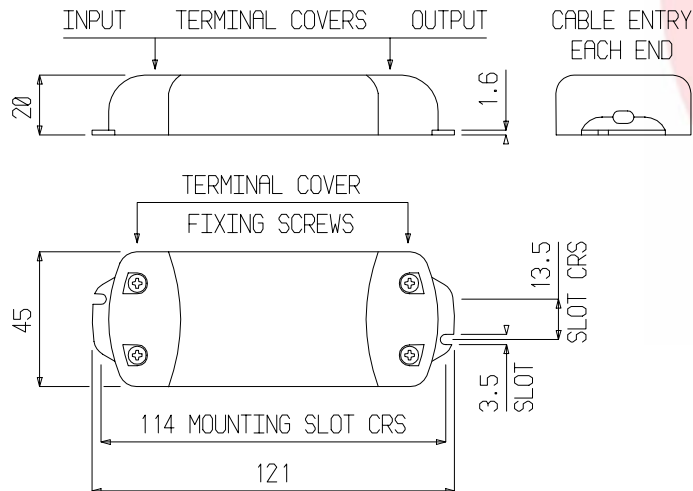

## Applications

Specifically designed to drive high power LED lamps including

- Spot lighting systems
- Architectural lighting systems
- Point of sale signs
- Display illumination

## Mechanical information

Dimensions	See package outline
Unit weight	70 g
AC input connections	Screw clamp terminals
Lamp output connections	Screw clamp terminals
Unit mounting	Two 3 mm screws

## Lamp Electrical Connections

Only LED lamps must be connected to the power driver

A minimum of one 3W LED lamp must be connected to the power driver

A maximum of four 3W LED lamps can be connected to the power driver

The LED lamps must be connected in series (see sheet 2)

The forward voltage of the LED lamp chain must not exceed 17 VDC

The power consumption of the LED lamps must not exceed 12 W

## Approvals



It is the responsibility of the customer to verify the suitability of the product for the application.

## Description

The LED Power Driver FE-LLD12700 is designed for driving Light Emitting Diode (LED) lamps from a 220 - 240 VAC supply. The driver is a switch mode power supply design having a constant current output of 700mA.

An electronic protection circuit switches off the LED Power Driver in case of the following problems:

- Short circuit
- Open circuit
- Secondary circuit overload
- Thermal overload

After faults are removed the LED Power Driver is ready for operation.

## Installation information

- The unit conforms to the following:
  - 2004/108/EC directive for electromagnetic compatibility
  - 73/23/EEC low voltage directive.
- The LED Power Driver is designed for used with LED lamps only.
- The LED Power Driver is only suitable for indoor use.
- The LED Power Driver should be prevented from over heating.
- The connected load must not fall below 3W or exceed 12W.
- Wire the LED lamps to the LED Power Driver with correct polarity according to the connection diagram.
- If the LED Power Driver is used for purposes other than originally intended or is connected incorrectly no liability can be taken for possible damages caused.

## Connection Diagram

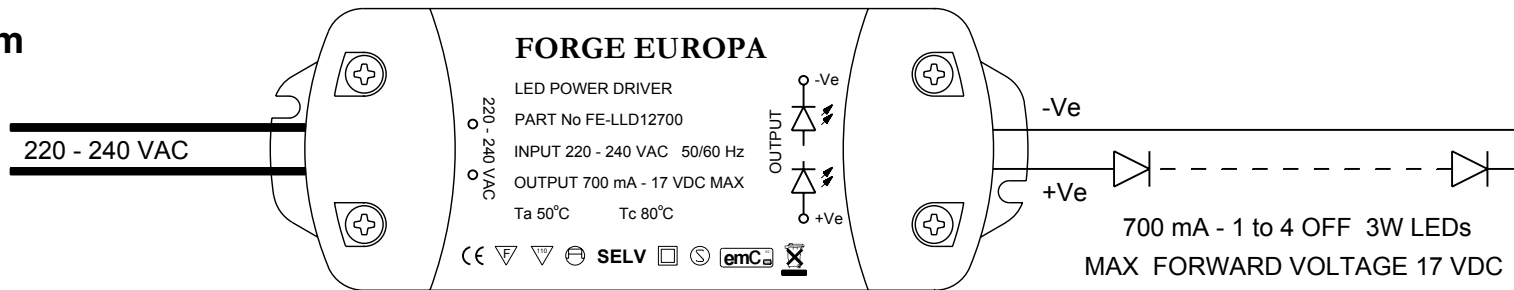

## Specification

Characteristic	Condition	Symbol	Rating	Units
Input voltage range		$V_{in}$	220-240	VAC
Input frequency		f	50/60	Hz
Power output range		$P_{och}$	3 min - 12 max	W
Output current	Steady state	$I_o$	700 $\pm$ 10%	mA
IP Rating			IP20	
Operating ambient temperature		$T_a$	-20 to +50	$^{\circ}$ C
Storage Temperature		$T_s$	-20 to +80	$^{\circ}$ C
Case temperature		$T_c$	+80 max	$^{\circ}$ C